

Securistyle Defender

Friction hinge

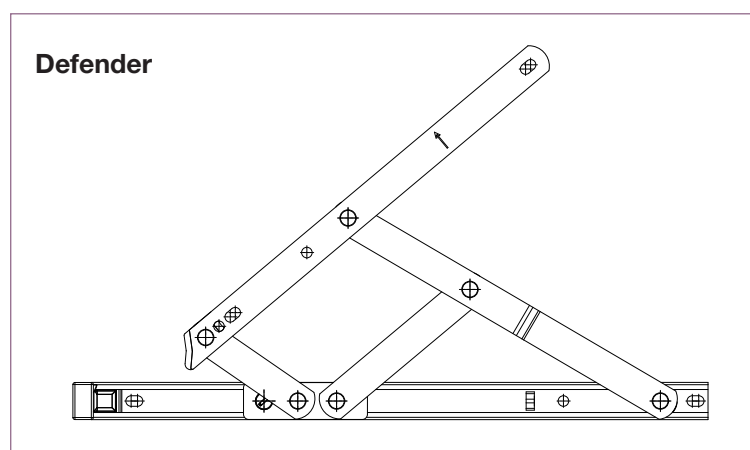

Features and Benefits

- Adjustable and controlled friction for smooth operation
- Efficient locating system by means of a patented asymmetrical end cap
- Extended enclosed end cap for enhanced weather sealing
- 13, 16 & 17mm stack heights
- Austenitic stainless steel versions available for high corrosion resistance
- Can be supplied with built-in restrictor
- Easy Clean and Fire Egress versions available
- Vector Excluder Security device available to improve security
- Defender Plus version offers increased carrying capacity

