

DEFENDER RESTRICTED

Friction hinge for
child safety

DEFENDER RESTRICTED

FRICION HINGE
FOR CHILD SAFETY

- Built-in child resistant mechanism limits initial opening
- **NEW extended enclosed end cap** to enhance weather sealing
- Tested to BS6375 Part 2 to withstand a force of 600N when opened to the restricted position
- Built-in quick release lever allows the window to be fully opened for easy cleaning, total ventilation
- **NEW handed 'profiled' vent arm** further enhancing weather seal
- Restrictor automatically relocates and resets when the window is closed
- Available in ferritic 430* and austenitic 304* stainless steel for enhanced corrosion resistance
- 10 year guarantee (details available upon request)

▼ QUICK RELEASE

Fully opening release lever relocates and resets automatically

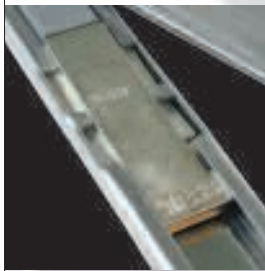

▼ SMOOTH OPERATION

Thermoplastic components for long life



* Standard Ferritic (was 430) steel to BS EN ISO 10088/2 Grade 1.4016 or Austenitic (was 304) stainless steel to BS EN ISO 10088/2 Grade 1.4301 for enhanced corrosion resistance.



Manufactured in UK

DEFENDER RESTRICTED

Product Specification

PRODUCT SPECIFICATION

- **NEW slot hole slot** format will provide the ability to adjust the vent more easily.
- **NEW increased carrying capacity** on 20" and 24" top hung hinges
- Side hung restricted hinges are sold singularly as only one side hung restricted hinge is required and is fitted as the bottom hinge. Top hung restricted hinges are sold in pairs
- Drilling jigs for all sizes are available to order

Note: as with all types of friction hinges, friction cannot be provided until the slider moves, therefore when limiting the opening of vents to angles of 10° or less, a separate device will be required to prevent the window from closing.

The restricted opening gap is controlled by;

- The restricted opening angle shown (angle 'B')
- Profile thickness
- Vent size

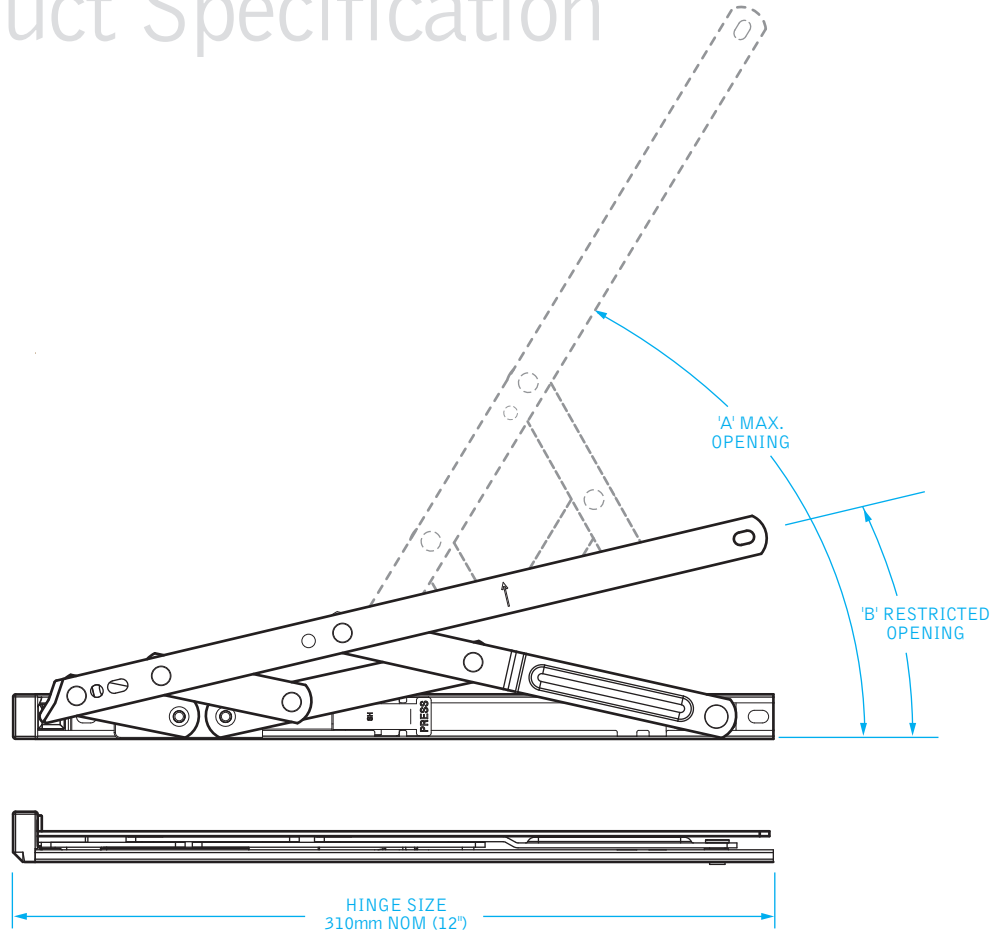

DEFENDER RESTRICTED

Hinge Size (Top Hung) (in/mm)	Max Vent Weight (lb/Kg)	Max Vent Height (in/mm)	Min Vent Height (in/mm)	Max Opening Angle 'A'	Max Opening Angle 'B'
12/310	44/20	21.7/550	13.8/350	65°	14°
16/413	46/21	29.5/780	19.7/500	59°	10°
20/513	57/26	43/1100	27.6/700	50°	7°
24/615	88/40	51/1300	33.5/850	37.5°	6°
Hinge Size (Side Hung)	Max Vent Width	Min Vent Width			
12/310	48/22	23.6/600	11.8/300	58°	13°
16/413	53/24	27.6/700	15.7/400	58°	11°



INVESTOR IN PEOPLE



BSEN ISO9001
 Cert No Q05105

Due to our policy of continual improvement we reserve the right to alter specifications without notice. It is the responsibility of the window manufacturer to ensure that the finished window meets the required performance and safety specification.

All transactions are subject to our standard conditions of supply, which are available on request.