

# DEFENDER 'SP'

Tough with high performance

## DEFENDER 'SP'

SPECIAL PURPOSE  
FRICTION HINGE

- Long and reliable working life tested to 50,000 cycles
- Asymmetric location system for reliable weather sealing to BS6375 Part 1
- Patented lipped slider for enhanced smooth operation
- Easy friction adjustment without metal to metal contact
- Unique patented, robust cam friction device eliminates any risk of friction screw misuse
- Austenitic 304 stainless steel for enhanced corrosion resistance
- Up to 90° opening
- Available with built in restrictors
- 10 year guarantee (details available upon request)



▼ Stainless steel reinforced slider for long life and strength.



▲ Austenitic 304 stainless steel for enhanced corrosion resistance.

# DEFENDER ROTOWINDER

## DEFENDER ROTOWINDER

SPECIAL PURPOSE  
FRICTION HINGE

- Long and reliable working life tested to 30,000 cycles
- Asymmetric location system for reliable weather sealing to BS6375 Part 1
- Patented lipped slider for enhanced smooth operation
- Easy friction adjustment without metal to metal contact
- Unique patented, robust cam friction device eliminates any risk of friction screw misuse
- Austenitic 304 stainless steel for enhanced corrosion resistance



▼ SMOOTH OPERATION  
Thermoplastic components for long life.



▼ WORLD'S BEST!  
The Defender is the World's best selling friction hinge.



# Product Specifications

DIMENSION 'L' WHEN HINGE IS FULLY OPEN

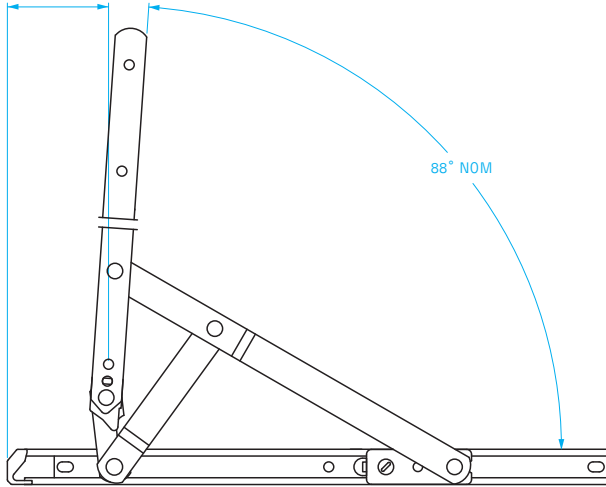

88° NOM

DIMENSION 'L' WHEN HINGE IS FULLY OPEN

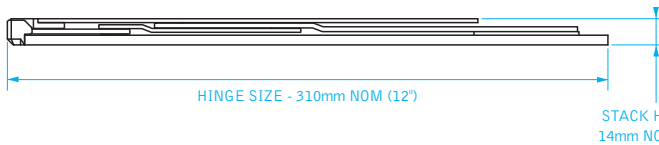
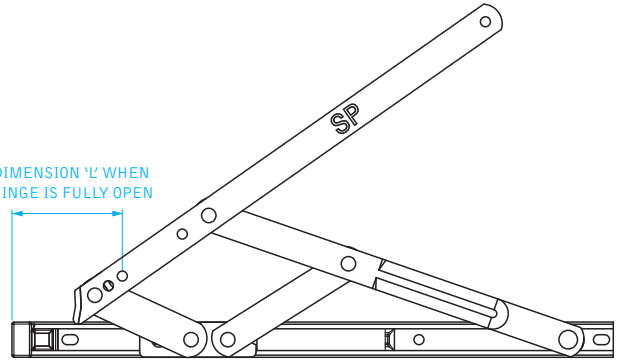

HINGE SIZE - 310mm NOM (12")

STACK HEIGHT 14mm NOMINAL

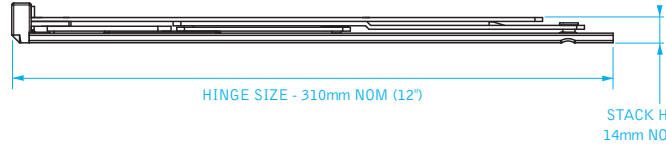

HINGE SIZE - 310mm NOM (12")

STACK HEIGHT 14mm NOMINAL

## ROTOWINDER

## DEFENDER 'SP'

## PRODUCT SPECIFICATIONS

### DEFENDER 'SP'

Hinge Code (Side Hung)	Max Vent Weight (lb/Kg)	Min. Vent Width (in/mm)	Max. Vent Width (in/mm)	Hinge Dimension 'L' (in/mm)	Restricted Angle (+/- 2.5°)	Opening Angle (+/- 2.5°)	TEST STANDARD
EDCSM12A-SP	46.3/21	11.8/300	23.6/600	5.1/131	-	90°	SISIR 212: 1988 &
EDCSR12A-SP	35.3/16	11.8/300	27.6/700	4.8/122	17°	83°	AAMA 904.1: 1987 & BS 6375 Pt 2
EDCSM16A-SP	52.9/24	15.7/400	35.4/900	8.6/220	-	90°	SISIR 212: 1998
EDCSR16A-SP	52.9/24	15.7/400	35.4/900	8.1/206	12.5°	83°	AAMA 904.1 : 1987 & BS 6375 Pt 2
EDCSM16A-SP	66.1/30	15.7/400	35.4/900	8.6/220	-	90°	AAMA 904.1 : 1987 & BS 6375 Pt 2
EDCSR16A-SP	66.1/30	15.7/400	35.4/900	8.1/206	12.5°	83°	AAMA 904.1: 1987 & BS 6375 Pt 2
EDSM16HA-SP	66.1/30	15.7/400	35.4/900	8.6/220	-	90°	AAMA 904.1: 1987 & BS 6375 Pt 2

### ROTOWINDER

Hinge Code (Side Hung)	Max Vent Weight (lb/Kg)	Min. Vent Width (in/mm)	Max. Vent Width (in/mm)	Hinge Dimension 'L' (in/mm)	Restricted Angle (+/- 2.5°)	Opening Angle (+/- 2.5°)	TEST STANDARD
DS12W2	44.1/20	11.8/300	22.3/600	2.0/52	-	88°	AAMA 904.1: 1987 & BS 6375 Pt 2

Note: Vent width is measured from rebate to rebate (not overall size or outer frame size) on conventional windows or glass size on structurally glazed windows e.g. curtain wall panels whichever is the greater dimension. For maximum vent height consult profile manufacturers for recommendations on requirements of system strength and sealing.

Note: Above sizes/weights also apply to DS12CASP15 (Highline).

Note: For slim aluminium systems these vent sizes may need to be reduced on restricted hinges to comply with a maximum restricted opening of 100mm. See chart in restricted section.

\*When fitting DSR12CASP & DSR16CASP a pair of restricted hinges must be fitted i.e. top and bottom of window, to achieve SISIR 212: 1988 & BS6375 Pt. 2



INVESTOR IN PEOPLE



DEFENDER HINGE ASSESSMENT NO. 192



BS EN ISO 9001 Cert No Q05105

Due to our policy of continual improvement we reserve the right to alter specifications without notice. It is the responsibility of the window manufacturer to ensure that the finished window meets the required performance and safety specification.

All transactions are subject to our standard conditions of supply, which are available on request.