

HINGES

ASSEMBLY SHEET - EDCSM12A-SP Side Hung Hinge

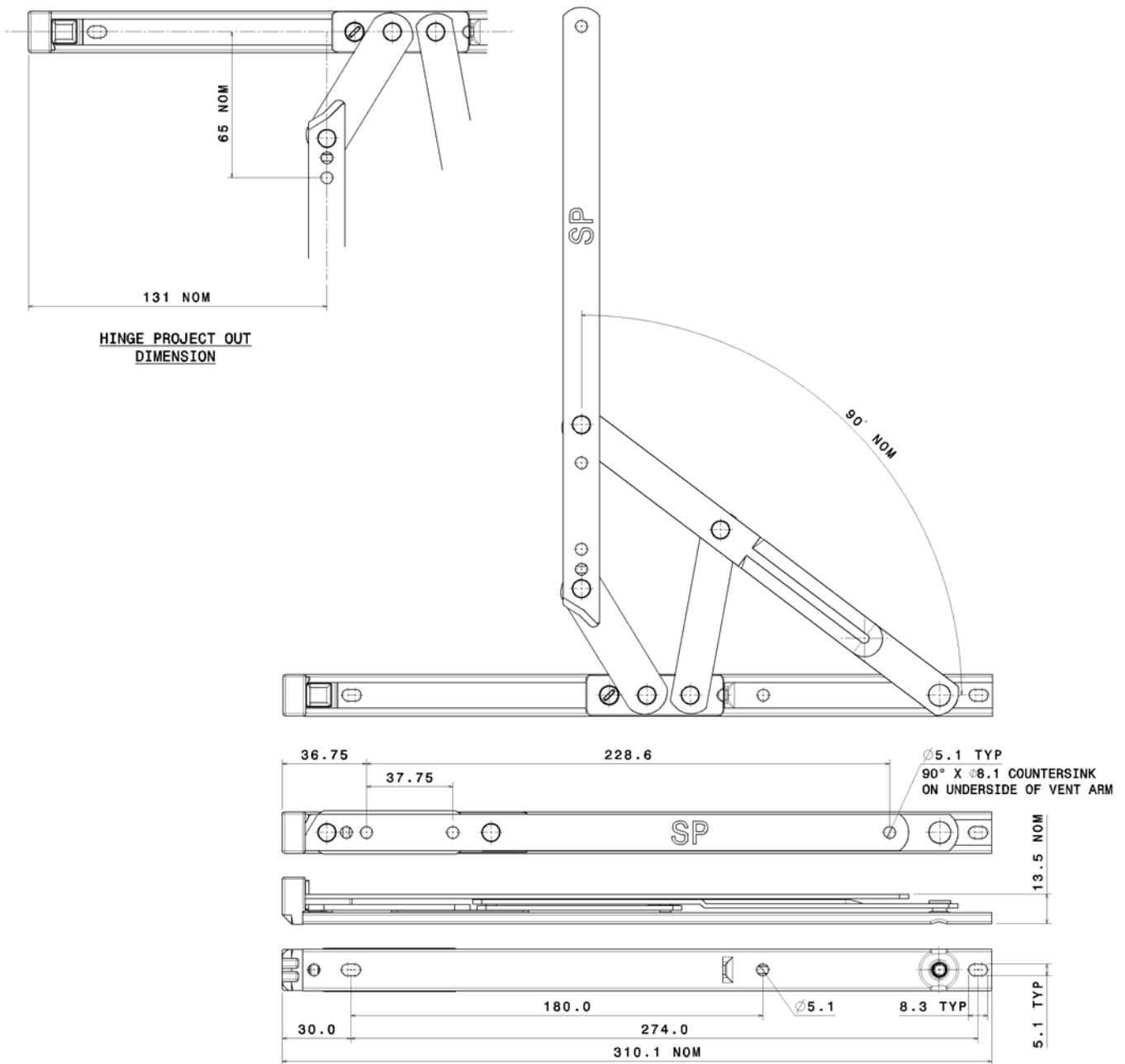

Hinge Code	Max. Vent Weight (Kg)	Min. Vent Width (mm)	Max. Vent Width (mm)	Max. Vent Height (mm)	Hardware Cavity (mm)
EDCSM12A-SP	21	300	600	See profile manufacturers recommendations	13.5 - 14.5
	16		700		

*Refer to Vent Size and Weight Chart for test standards applicable to sizes.

Not to Scale, All dimensions in mm

It is the responsibility of the user to ensure that this document is at the latest issue.

Due to our policy of continual product improvement we reserve the right to alter specifications without notice.

It is the responsibility of the window manufacturer to ensure that the finished window meets the required performance and safety specification.



Securistyle Ltd.
Kingsmead Industrial Estate
Princess Elizabeth Way, Cheltenham,
Gloucestershire, GL51 7RE
Tel: +44 (0) 1242 221200
Fax: +44 (0) 1242 520828
Web: www.securistyle.co.uk

HINGES

SPECIAL HINGES

SECTION 8.2 SHEET 2 of 8

ISSUE: March, 2006

ASSEMBLY SHEET - EDCSR12A-SP Side Hung Restricted Hinge

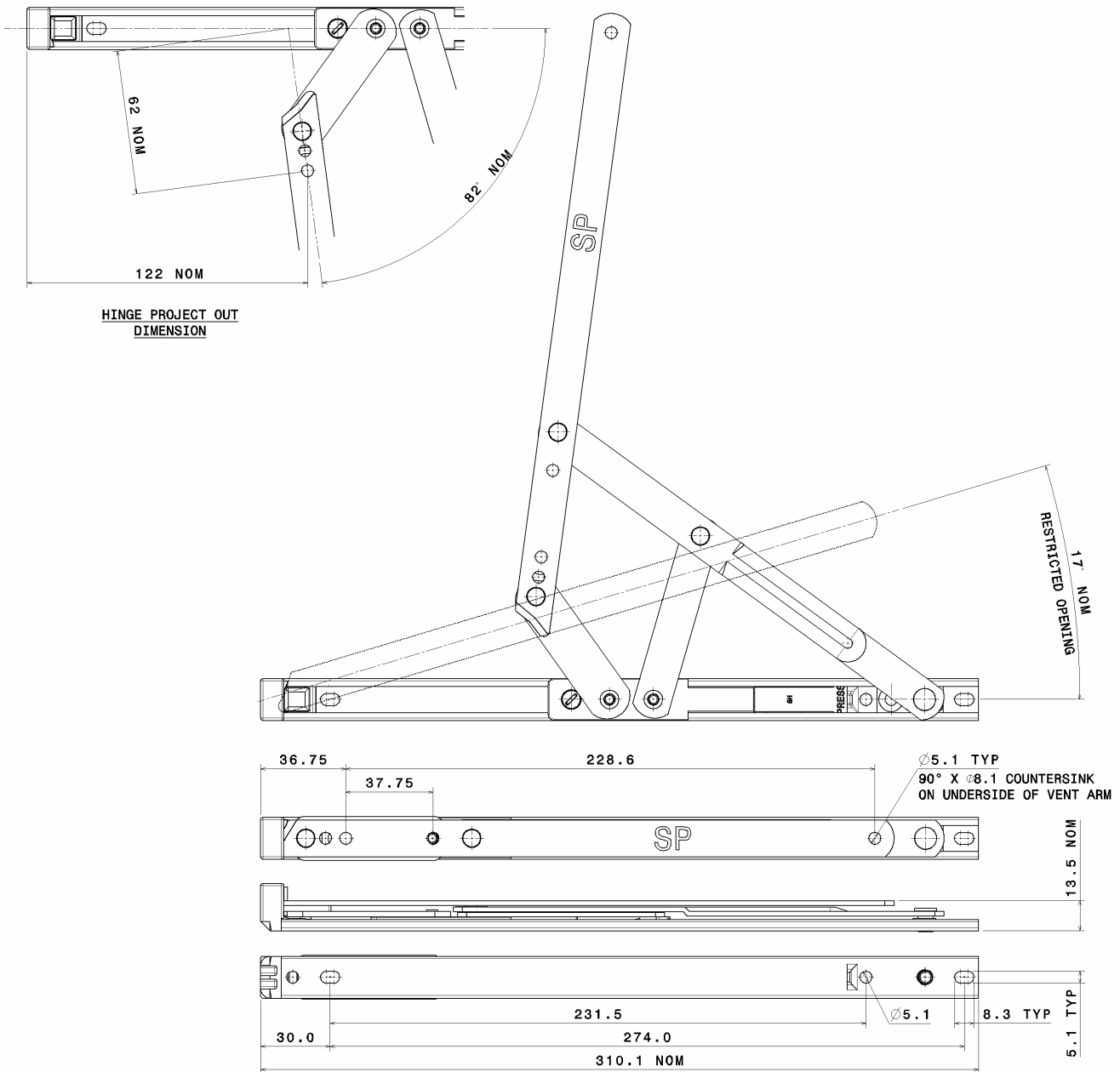

Hinge Code	Max. Vent Weight (Kg)	Min. Vent Width (mm)	Max. Vent Width (mm)	Max. Vent Height (mm)	Hardware Cavity (mm)
EDCSR12A-SP	21	300	600	See profile manufacturers recommendations	13.5 - 14.5
	16		700		

*Refer to Vent Size and Weight Chart for test standards applicable to sizes.

Not to Scale, All dimensions in mm

It is the responsibility of the user to ensure that this document is at the latest issue.

Due to our policy of continual product improvement we reserve the right to alter specifications without notice.

It is the responsibility of the window manufacturer to ensure that the finished window meets the required performance and safety specification.

© SECURISTYLE LTD 2006



Securistyle Ltd.
Kingsmead Industrial Estate
Princess Elizabeth Way, Cheltenham,
Gloucestershire, GL51 7RE
Tel: +44 (0) 1242 221200
Fax: +44 (0) 1242 520828
Web: www.securistyle.co.uk

HINGES

ASSEMBLY SHEET - EDCSM16A-SP

Side Hung Hinge

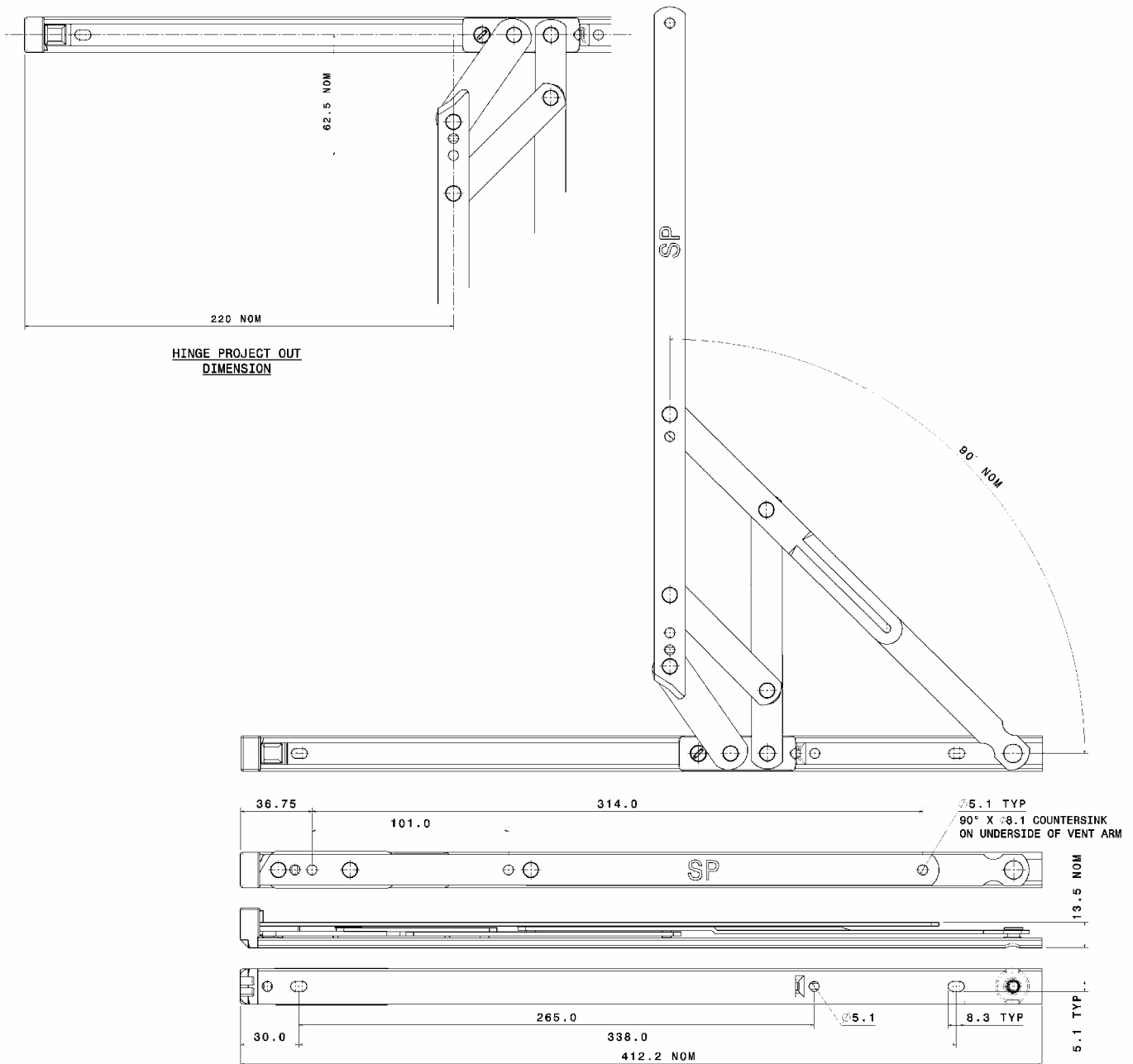

Hinge Code	Max. Vent Weight (Kg)	Min. Vent Width (mm)	Max. Vent Width (mm)	Max. Vent Height (mm)	Hardware Cavity (mm)
EDCSM16A-SP	24	400	900	See profile manufacturers recommendations	13.5 - 14.5
	30		900		

*Refer to Vent Size and Weight Chart for test standards applicable to sizes.

Not to Scale, All dimensions in mm

It is the responsibility of the user to ensure that this document is at the latest issue.

Due to our policy of continual product improvement we reserve the right to alter specifications without notice.

It is the responsibility of the window manufacturer to ensure that the finished window meets the required performance and safety specification.



Securistyle Ltd.
 Kingsmead Industrial Estate
 Princess Elizabeth Way, Cheltenham,
 Gloucestershire, GL51 7RE
 Tel: +44 (0) 1242 221200
 Fax: +44 (0) 1242 520828
 Web: www.securistyle.co.uk

HINGES

ASSEMBLY SHEET - EDCSR16A-SP Side Hung Restricted Hinge

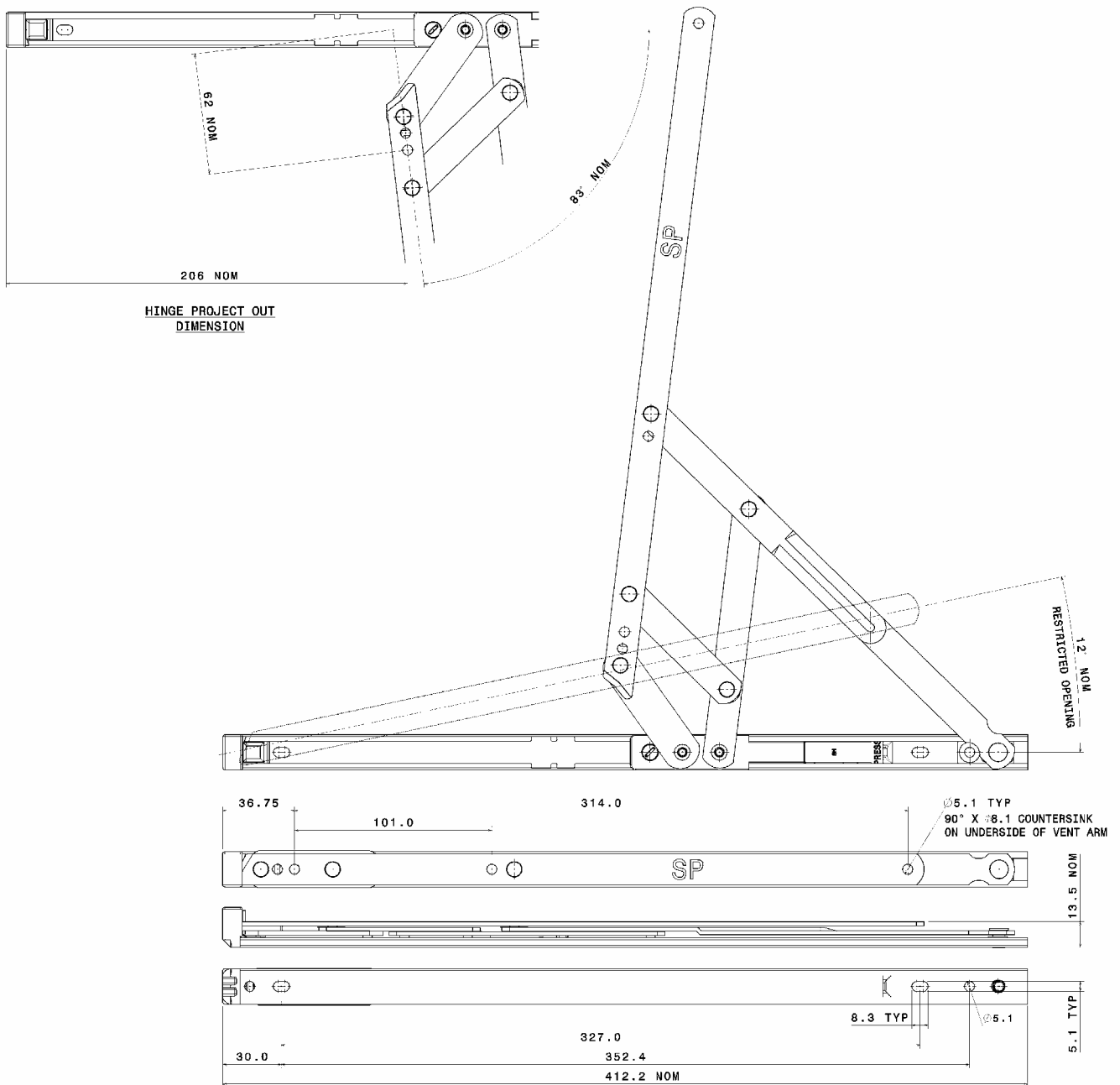

Hinge Code	Max. Vent Weight (Kg)	Min. Vent Width (mm)	Max. Vent Width (mm)	Max. Vent Height (mm)	Hardware Cavity (mm)
EDCSR16A-SP	24	400	900	See profile manufacturers recommendations	13.5 - 14.5
	30		900		

* Refer to Vent Size and Weight Chart for test standards applicable to sizes.

Not to Scale, All dimensions in mm

It is the responsibility of the user to ensure that this document is at the latest issue.

Due to our policy of continual product improvement we reserve the right to alter specifications without notice.

It is the responsibility of the window manufacturer to ensure that the finished window meets the required performance and safety specification.



Securistyle Ltd.
Kingsmead Industrial Estate
Princess Elizabeth Way, Cheltenham,
Gloucestershire, GL51 7RE
Tel: +44 (0) 1242 221200
Fax: +44 (0) 1242 520828
Web: www.securistyle.co.uk

HINGES

SPECIAL HINGES

SECTION 8.2 SHEET 5 of 8

ISSUE: March, 2006

ASSEMBLY SHEET - EDSM16HA-SP Side Hung Hinge

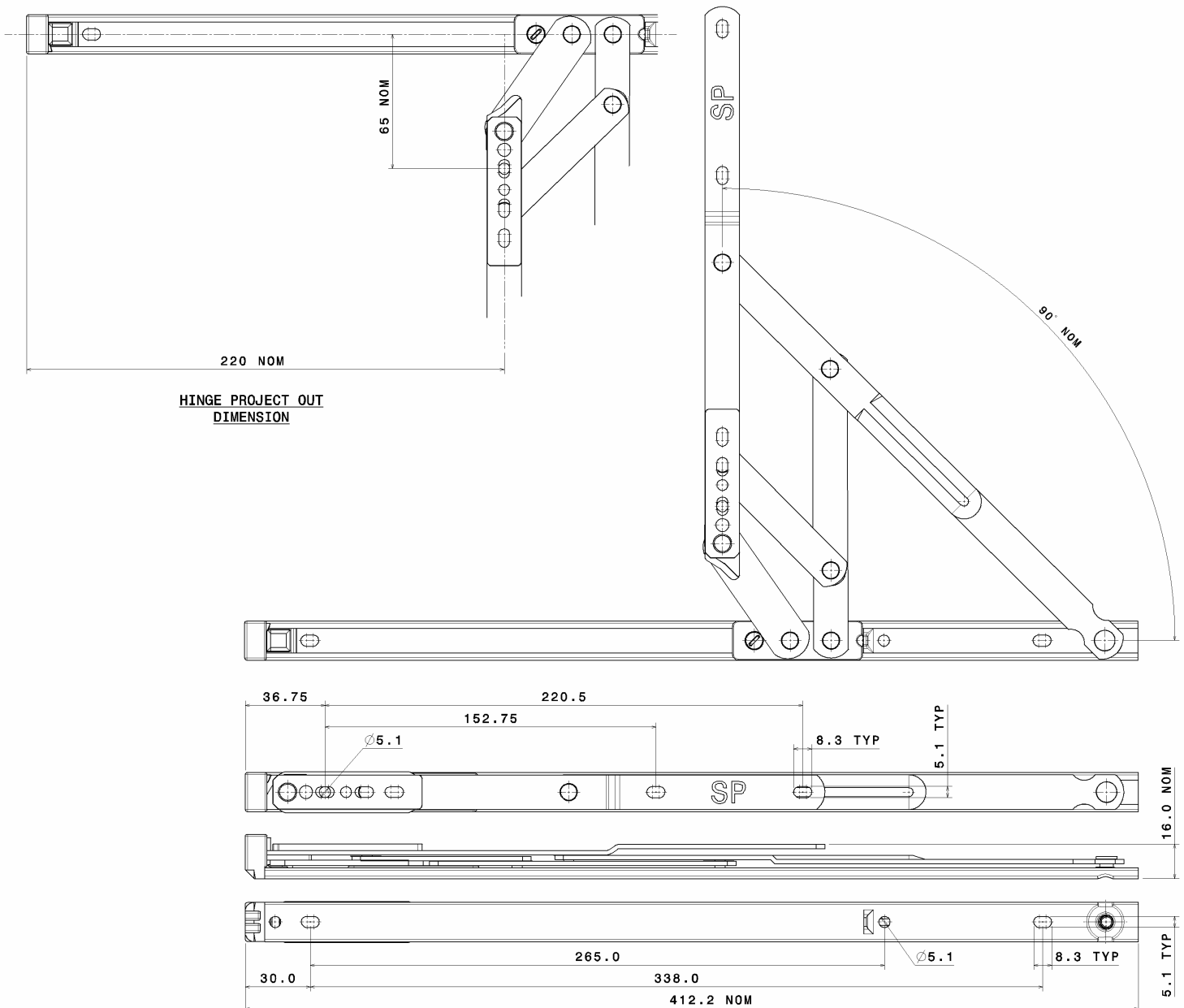

Hinge Code	Max. Vent Weight (Kg)	Min. Vent Width (mm)	Max. Vent Width (mm)	Max. Vent Height (mm)	Hardware Cavity (mm)
EDSM16HA-SP	24	400	900	See profile manufacturers recommendations	15 - 16
	30		900		

* Refer to Vent Size and Weight Chart for test standards applicable to sizes.

Not to Scale, All dimensions in mm

It is the responsibility of the user to ensure that this document is at the latest issue.

Due to our policy of continual product improvement we reserve the right to alter specifications without notice.

It is the responsibility of the window manufacturer to ensure that the finished window meets the required performance and safety specification.



Securistyle Ltd.
 Kingsmead Industrial Estate
 Princess Elizabeth Way, Cheltenham,
 Gloucestershire, GL51 7RE
 Tel: +44 (0) 1242 221200
 Fax: +44 (0) 1242 520828
 Web: www.securistyle.co.uk

HINGES

ASSEMBLY SHEET - DS12W2

Side Hung Hinge

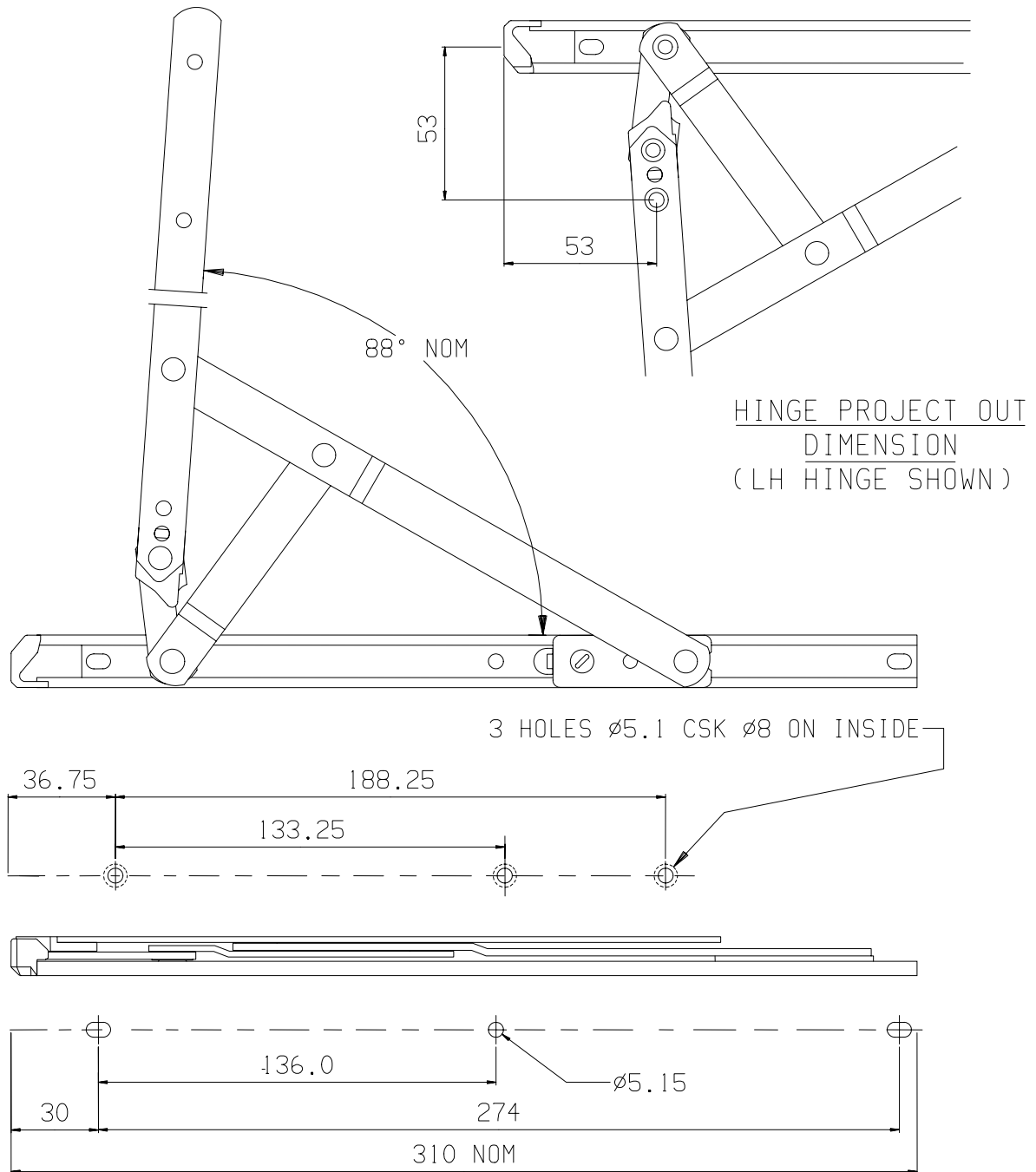

Hinge Code	Max. Vent Weight (Kg)	Min. Vent Width (mm)	Max. Vent Width (mm)	Max. Vent Height (mm)	Hardware Cavity (mm)
DS12W2	20	300	600	See profile manufacturers recommendations	13.5 - 14.5

Not to Scale, All dimensions in mm

It is the responsibility of the user to ensure that this document is at the latest issue.

Due to our policy of continual product improvement we reserve the right to alter specifications without notice.

It is the responsibility of the window manufacturer to ensure that the finished window meets the required performance and safety specification.



Securistyle Ltd.
 Kingsmead Industrial Estate
 Princess Elizabeth Way, Cheltenham,
 Gloucestershire, GL51 7RE
 Tel: +44 (0) 1242 221200
 Fax: +44 (0) 1242 520828
 Web: www.securistyle.co.uk

HINGES

ASSEMBLY SHEET - EDT10-S Top Hung Hinge

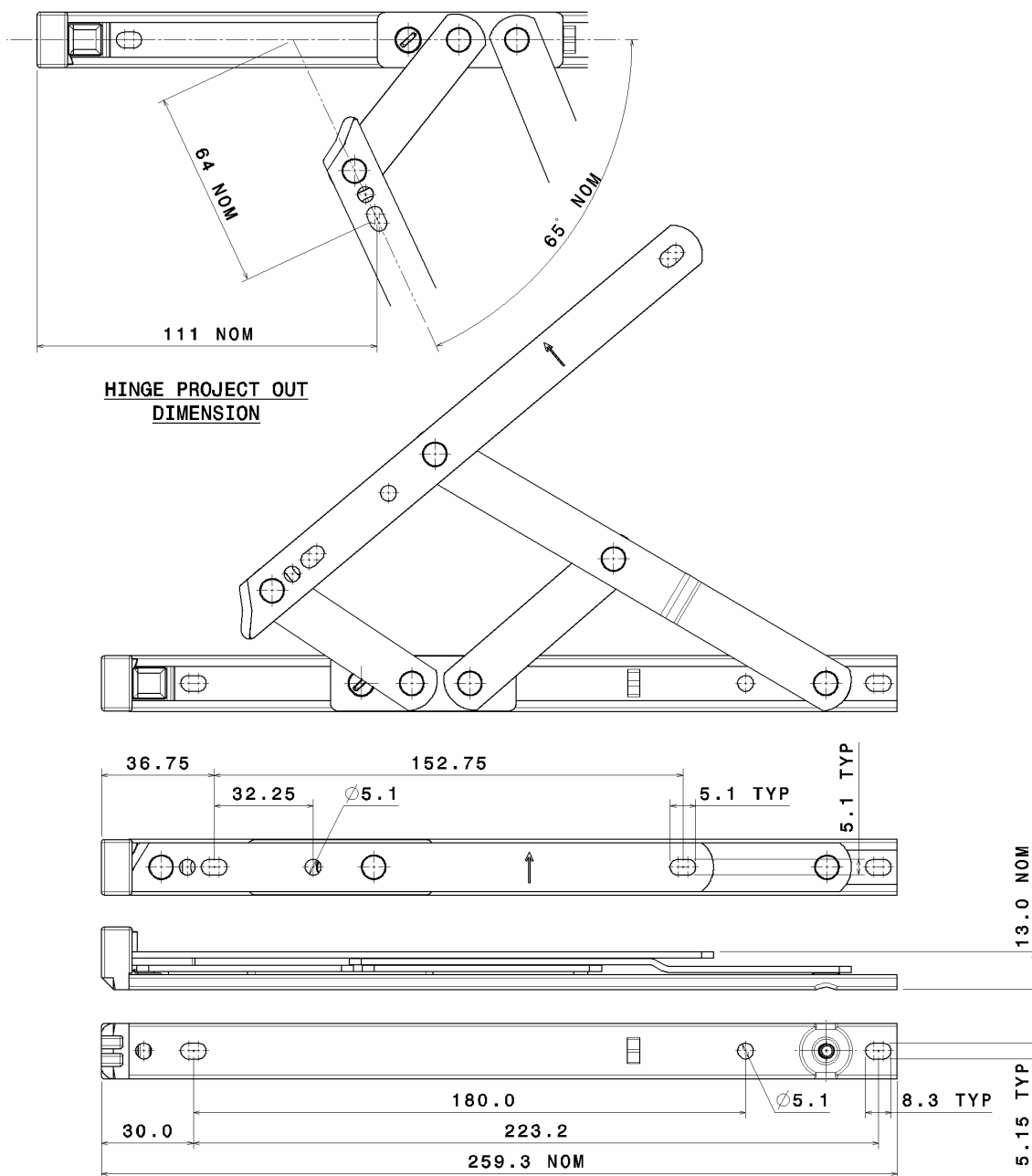

Hinge Code	Max. Vent Weight (Kg)	Min. Vent Height (mm)	Max. Vent Height (mm)	Max. Vent Width (mm)	Hardware Cavity (mm)
EDT10-S	16	275	400	See profile manufacturers recommendations	13 - 14

*Opening angle reduced from 80° on the standard DT10 hinge.

Not to Scale, All dimensions in mm

It is the responsibility of the user to ensure that this document is at the latest issue.

Due to our policy of continual product improvement we reserve the right to alter specifications without notice.

It is the responsibility of the window manufacturer to ensure that the finished window meets the required performance and safety specification.



Securistyle Ltd.
 Kingsmead Industrial Estate
 Princess Elizabeth Way, Cheltenham,
 Gloucestershire, GL51 7RE
 Tel: +44 (0) 1242 221200
 Fax: +44 (0) 1242 520828
 Web: www.securistyle.co.uk

HINGES

ASSEMBLY SHEET - EDT12-S Top Hung Hinge

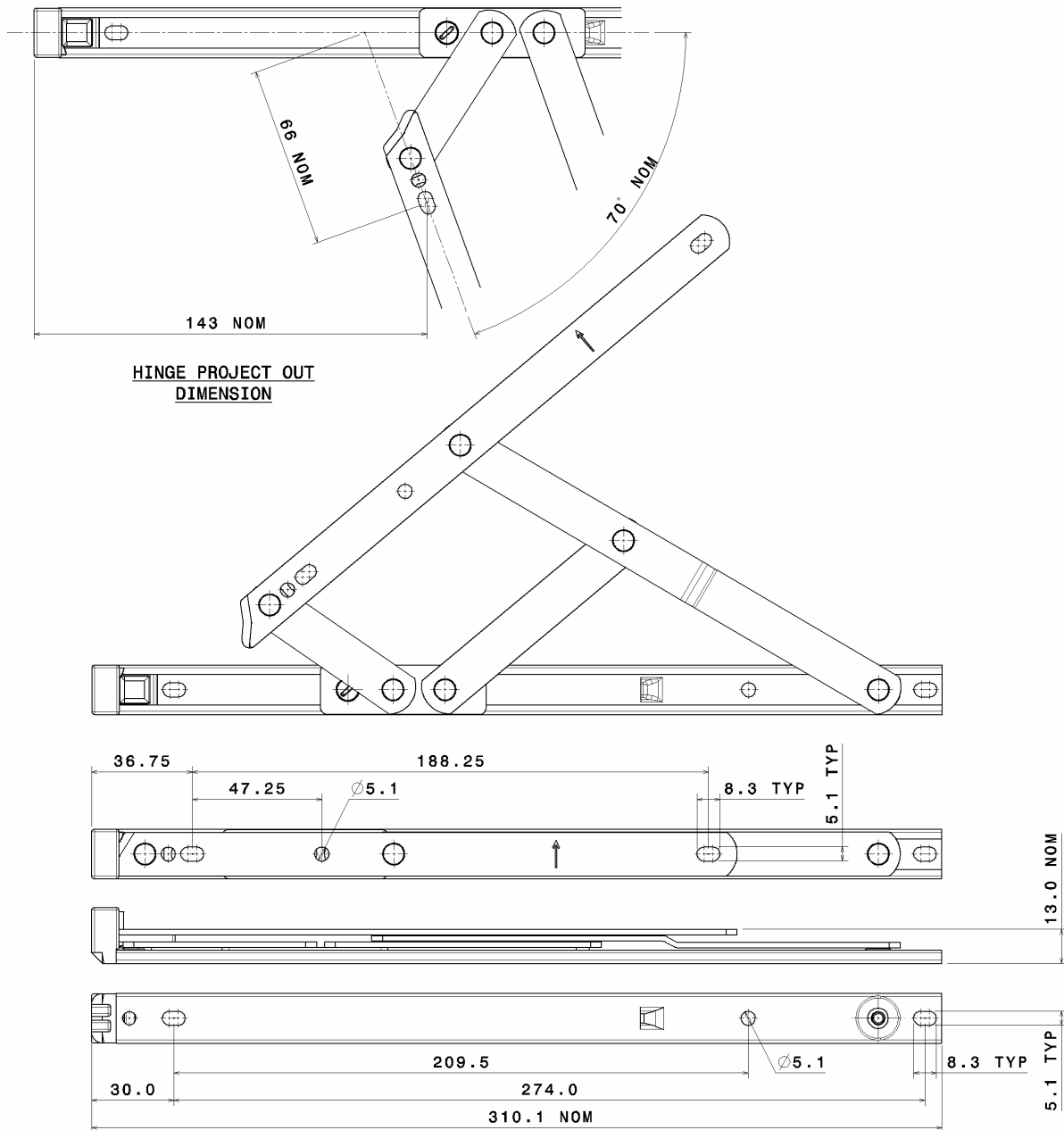

Hinge Code	Max. Vent Weight (Kg)	Min. Vent Width (mm)	Max. Vent Width (mm)	Max. Vent Height (mm)	Hardware Cavity (mm)
EDT12-S	20	350	550	See profile manufacturers recommendations	13 - 14

*Opening angle reduced from 80° on the standard DT12 hinge.

Not to Scale, All dimensions in mm

It is the responsibility of the user to ensure that this document is at the latest issue.

Due to our policy of continual product improvement we reserve the right to alter specifications without notice.

It is the responsibility of the window manufacturer to ensure that the finished window meets the required performance and safety specification.



Securistyle Ltd.
 Kingsmead Industrial Estate
 Princess Elizabeth Way, Cheltenham,
 Gloucestershire, GL51 7RE
 Tel: +44 (0) 1242 221200
 Fax: +44 (0) 1242 520828
 Web: www.securistyle.co.uk