

Maxiglaze

Energy efficient glazed-in ventilator

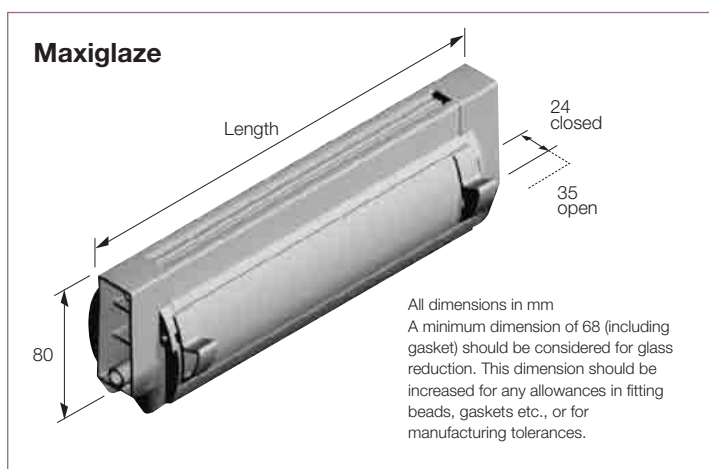

Features and Benefits

- Optimum air opening over length
- 2500mm² EA / 4600mm² Free Area at 270mm long, 5000mm² EA / 8900mm² Free Area at 470mm long
- Made-to-measure
- For 20, 24 or 28mm glass units
- Vent Injection Process (VIP); rapid sealing method to improve weather tightness
- Dual colour (inner and outer) finish available
- Thermally improved
- Channel gasket
- Gas Regulations version
- Cord and rod control options
- Patented design

Performance

(Full test details available on request)

Equivalent Area (EA) (mm²)

12000 per metre of extrusion

Free Area (mm²)

21476 per metre of extrusion

Air Leakage (m³/hr @ 50Pa)

500mm overall length - 0.98

Water Resistance (Pa)

600

Acoustic D_{n,e,w} (+/-)

500mm overall length -

vent open 29 (0;0)

vent closed 48 (-1;-3)

