

Maxiglaze

Energy efficient glazed-in ventilator



Maxiglaze Ventilator (inside)

Maxiglaze Ventilator (outside)

For use on PVCu, timber* or aluminium windows

Maxiglaze is an energy efficient glazed-in aluminium ventilator that provides an Equivalent Area (EA) of 12000mm² per metre of extrusion (equal to vent length minus 57mm). Optimum performance over length

requires fewer vents to be fitted to achieve total requirement. The Maxiglaze is available in made to measure sizes or in bar length in a variety of colours.



Features and Benefits

- Optimum air opening over length
- 2500mm² EA / 4600mm² Free Area at 270mm long, 5000mm² EA / 8900mm² Free Area at 470mm long
- Supplied made-to-measure or in bar length
- Designed for easy cutting and assembly from bar length
- Suitable for 20, 24 or 28mm glass thicknesses
- Available in mill finish bar length for customer painting (24mm version only)
- Vent Injection Process (VIP); rapid sealing method to improve weather tightness
- Aluminium or (white) plastic canopy
- Dual colour (inner and outer) finish available
- Thermally improved (not mill finish version). Complies with BS5440 Part 2
- Channel gasket
- Available in Gas Regulations version
- Cord and rod control versions
- Patented design
- When specified correctly complies with Building Regulations

*Suitability on timber windows dependent on bead fitting method and sealing. Please phone for further details.



Cord operation

Rod Operation

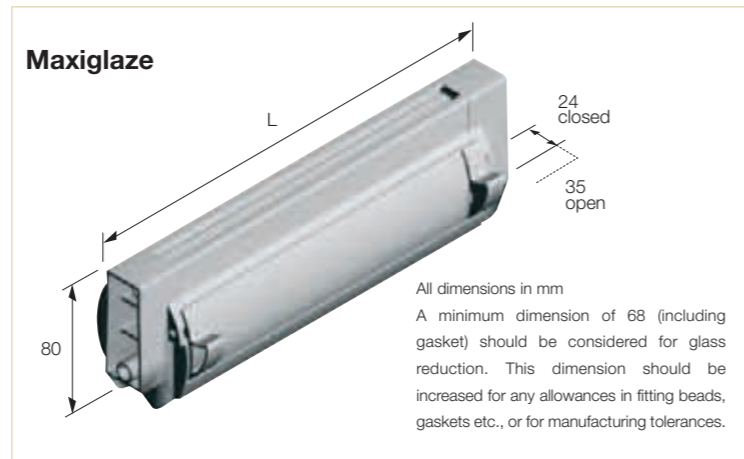

Manufactured from

Aluminium 6063 HIT T6, component parts PVCu, POM, PA6 & PP (UV Stable)

Standards

Tested in accordance with BS EN 13141-1:2004 (air flow, air leakage and weather tightness)

Gas Regulations version designed to comply with Building Regulations (England & Wales) Approved Document J and BS 5440 Part 2:2000

Acoustic performance tested in accordance with BS EN ISO20140-10:1992, BS EN ISO140-10:1991 and single figures to BS EN ISO717-1:1991

Performance

(Full test details available on request)
 Equivalent Area (EA) (mm²) – 12000 per metre of extrusion
 Free Area (mm²) – 21476 per metre of extrusion
 Air Leakage (m³/hr @ 50Pa) – 500mm overall length - 0.98
 Water Resistance (Pa) – 600
 Acoustic D_{n,e,w} (+/-) – 500mm overall length - vent open 29 (0;0), vent closed 48 (-1;-3)

Finishes

Suffix product code with:
 -387 (white with PVCu canopy), -020 (white with white aluminium canopy), -475 (white with black aluminium canopy)
 *This product cannot be supplied anodised

More information

enquiries@titon.co.uk / 01206 713801

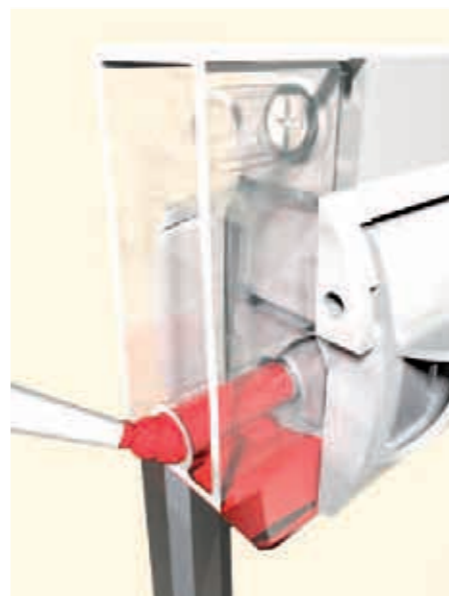

VIP

Details

Length	Product Code		
	20mm Glass Thickness	24mm Glass Thickness	28mm Glass Thickness
207-399	GV18301	GV18401	GV18501
400-499	GV18302	GV18402	GV18502
500-599	GV18303	GV18403	GV18503
600-699	GV18304	GV18404	GV18504
700-799	GV18305	GV18405	GV18505
800-899	GV18306	GV18406	GV18506
900-999	GV18307	GV18407	GV18507
1000-1099	GV18308	GV18408	GV18508
1100-1199	GV18309	GV18409	GV18509
1200-1299	GV18310	GV18410	GV18510
1300-1399	GV18311	GV18411	GV18511
1400-1499	GV18312	GV18412	GV18512
1500-1599	GV18313	GV18413	GV18513
1600-1699	GV18314	GV18314	GV18314
1700-1799	GV18315	GV18315	GV18315
cord control	TA18002/012 Black or TA18002/392 White		
rod control 600mm rod pack	TA18003/012 Black or TA18003/392 White		
rod control 1000mm rod pack	TA18004/012 Black or TA18004/392 White		

Vent supplied with unrestricted Equivalent Area over length. Product can be supplied with Equivalent Area limited to 2500 or 5000mm² EA figures above and marked on vents are achieved when fitted to manufacturer's recommendations. Tested in accordance with BS:EN 13141-1 (2004).

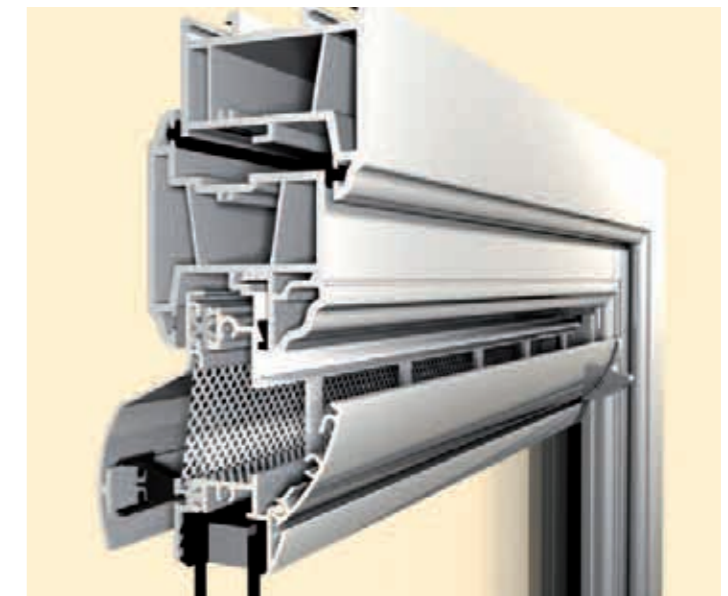

Over glass