

- Do not pull extrusions from end of box
- Open box carefully along length
- Support extrusions along length when carrying

For Each Ventilator You Will Need:-

- Assembled extrusions with canopy supports fitted.
- 4 screws, pair of endcaps & pair of snibs.
- Coil of mesh.
- Blanking Strips (Optional)
- Closure Clip
- EA Sticker

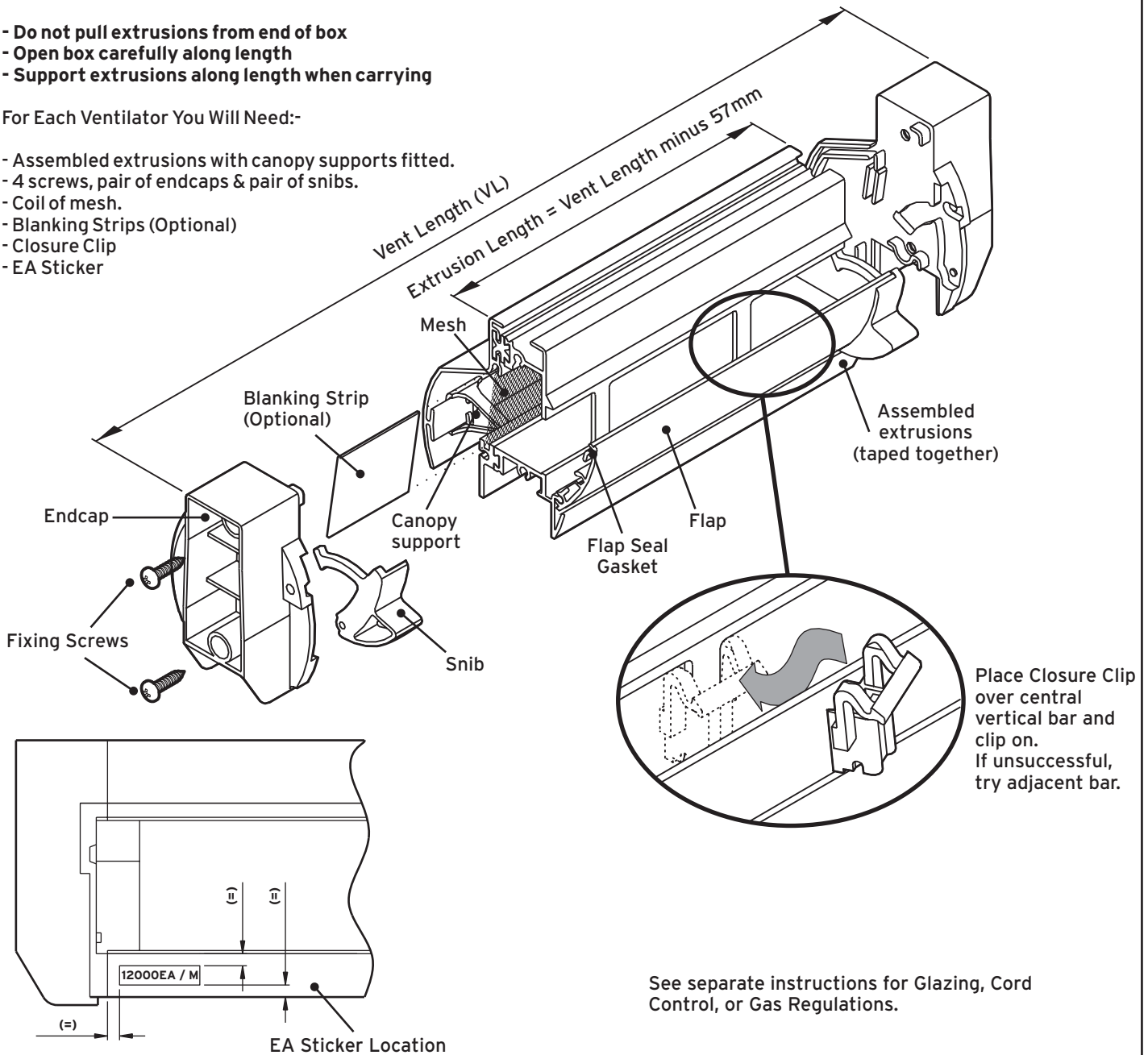

See separate instructions for Glazing, Cord Control, or Gas Regulations.

**Blanking strip available to reduce EA per metre. These cannot be fitted after vent assembly. Please phone for details.**

1. Cut assembled extrusions together, starting from **non-taped** end. Ensure all are same length and cut square. Ensure flap seal gasket is still in position.
2. Fit one snib to end of flap then screw on corresponding endcap, ensuring snib locates correctly in end cap.
3. Ensure canopy supports are positioned equally along length. 200mm apart when using a plastic hood (300mm for aluminium).
4. If required, cut mesh to same length as extrusions and slide in.
5. Cut blanking strip and slide in over mesh, into mesh channel. For length see panel right.
6. Fit remaining snib then screw on endcap.
7. Closure Clip - vents over 790mm long, see detail.
8. Check vent opens and closes smoothly.
9. Affix EA sticker in position shown.

**EA performance = 12,000 EA (mm<sup>2</sup>) per metre for extrusion length.**

#### Blanking Strip Details

Equivalent Area (EA) mm <sup>2</sup>	Blanking Strip Length Reqd
2,500	VL minus 270mm
5,000	VL minus 470mm
Full	No Strip Reqd
Blanking strips less than 40mm are not required.	