

Diagram

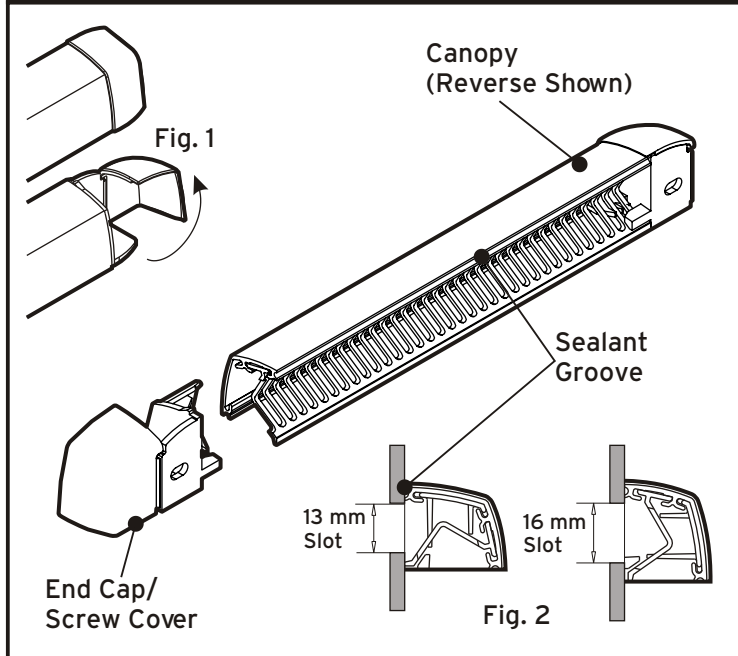

Instructions

1. Jig drill pilot fixing holes on slot centreline at recommended centres (see relevant slot details).
2. Open Screw Covers on end caps by unclipping flap and hinging outwards. See inset Fig 1.
3. Ensure canopy is fitted correct way round depending on 13 or 16mm slot requirement. See inset Fig 2.
4. Apply good quality silicone sealant to sealant groove.
5. Loosely screw both ends of canopy in place then, holding canopy firmly against window section, securely tighten screws. **DO NOT OVER TIGHTEN!**
6. Engage screw covers by closing back to original position. See inset Fig 1.